



ESTUN AUTOMATION CO.,LTD.



No.1888, Jiyin Road, Jiangning Development Zone, Nanjing 211106, P.R.China
No.16, Shuige Road, Jiangning Development Zone, Nanjing 211106, P.R.China
No.178, Yanhu Road, Jiangning Development Zone, Nanjing 211106, P.R.China
No.155, Jiangjun Road, Jiangning Development Zone, Nanjing 211106, P.R.China



+86-25-52785866



+86-25-52785966



www.estun.com

Service Hotline +86 400 025 3336



Wechat



Website

V2.1

ProNet Plus Series
Full Digital AC Servo Systems



ALL DIGITAL AC SERVO SYSTEMS

ESTUN Automation Co. Ltd. started its business in offering an automation control system for Metal Forming Machinery in 1993 at Nanjing, China. Now ESTUN Automation becomes a leading global product, system and service provider of key industrial automation components/systems, industrial robots and advanced intelligent manufacturing systems.

The Automation Business Group of ESTUN Automation offers a comprehensive product portfolio of servo and motion control products/systems/solutions for General Motion Control and Metal Forming applications. Servo drives, servo motors and EtherCAT based servo systems have been widely used for various Machine Automation applications and served for its global and domestic customers for more than 17 years.

As a global company, ESTUN Automation has 7 oversea branches and serves customers in more than 60 countries and regions. ESTUN Automation will relentlessly pursuing the excellence in Advanced Motion control solutions, Industrial Robotics (as well as service Robots for rehabilitation, etc.) and Intelligent Manufacturing Systems through collaborating with global subsidiaries and partners, such as Trio Motion Technology; ESTUN Industrial Technology, Europe; M.A.I. GmbH & Co. KG; Euclid Lab; Barrett Technology, etc. in better serving its global customers.

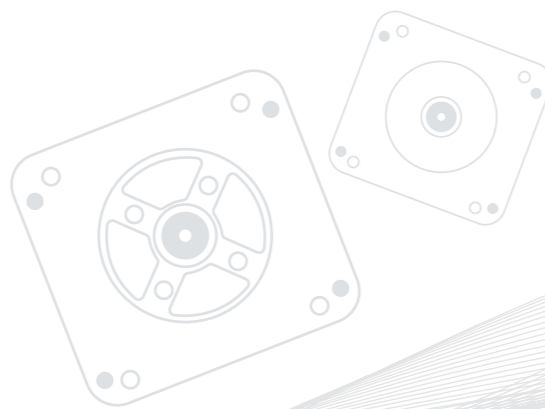
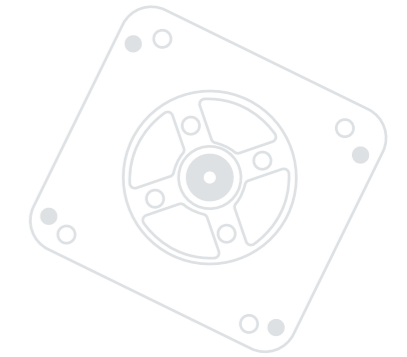

Model Comparison Table 03

Servo Drive 05

Servo Motor 08

Wiring 17

Accessories 18

CONTENTS



01

MODEL COMPARISON TABLE

Servo Motor	Power	Model	Servo Drive	Voltage	Encoder Cables	Power Cables	Brake Connector			
EMJ 3000r/min	0.2	EMJ-02ASA□□	PRONET-02AEG-EC	Single-phase 200VAC	PDP-JE24-05(Absolute,waterproof)	PDM-JE18-05(waterproof)	EMJ Brake Connector			
		EMJ-02AFD□□	PRONET-02AMG		PBP-JE24-05 (Incremental,waterproof)					
	0.4	EMJ-04ASA□□	PRONET-04AEG-EC PRONET-04AMG	Single-phase 200VAC	PDP-JE24-05(Absolute,waterproof)					
		EMJ-04ASH□□			PDP-JE24-05(Absolute,waterproof)					
		EMJ-04AFD□□			PBP-JE24-05 (Incremental,waterproof)					
		EMJ-04AFM□□			PBP-JE24-05 (Incremental,waterproof)					
	0.75	EMJ-08ASB□□	PRONET-08AEG-EC PRONET-08AMG		PDP-JE24-05(Absolute,waterproof)					
		EMJ-08AFD□□			PBP-JE24-05 (Incremental,waterproof)					
	1	EMJ-10ASB□□	PRONET-10AEG-EC PRONET-10AMG		PDP-JE24-05(Absolute,waterproof)					
		EMJ-10AFD□□			PBP-JE24-05 (Incremental,waterproof)					
	EM3A 3000r/min	0.05	EM3A-A5ALA2□□	PRONET-A5AMG PRONET-A5AEG-EC	Single-phase 200VAC			PDP-JB24-XX PBP-JB24-XX	PDM-JB18-XX (Without Brake) PDMB-JB18-XX (With Brake)	-
		0.1	EM3A-01ALA2□□	PRONET-01AMG PRONET-01AEG-EC	Single-phase 200VAC			PDP-JB24-XX PBP-JB24-XX		
0.2		EM3A-02ALA2□□	PRONET-02AMG PRONET-02AEG-EC	Single-phase 200VAC	PDP-JB24-XX					
		EM3A-02AFA2□□			EC3S-A2724-XX (waterproof) PBP-JB24-XX					
0.4		EM3A-04ALA2□□	PRONET-04AMG PRONET-04AEG-EC	Single-phase 200VAC	EC3S-I2724-XX (waterproof)					
		EM3A-04AFA2□□			PDP-JB24-XX EC3S-A2724-XX (waterproof) PBP-JB24-XX					
0.75		EM3A-08ALA2□□	PRONET-08AMG PRONET-08AEG-EC	Three-phase 200VAC	EC3S-I2724-XX (waterproof)					
		EM3A-08AFA2□□			PDP-JB24-XX EC3S-A2724-XX (waterproof) PBP-JB24-XX					
1		EM3A-10ALA2□□	PRONET-10AMG PRONET-10AEG-EC	Three-phase 200VAC	EC3S-I2724-XX (waterproof)					
		EM3A-10AFA2□□			PDP-JB24-XX EC3S-A2724-XX (waterproof) PBP-JB24-XX					
1.5		EM3A-15AFA2□□4	PRONET-15AMG PRONET-15AEG-EC	Three-phase 200VAC	PBP-GM24-XX					
		EM3A-15ALA2□□4			PDP-GA24-XX-II					
		EM3A-15DFM2□□4			PBP-GM24-XX					
2		EM3A-15DLA2□□4	PRONET-15DMG PRONET-15DEG-EC	Three-phase 400VAC	PDP-GA24-XX-II					
		EM3A-20AFA2□□4			PBP-GM24-XX					
		EM3A-20ALA2□□4			PDP-GA24-XX-II					
2		EM3A-20DFA2□□4	PRONET-20AMG PRONET-20AEG-EC	Three-phase 200VAC	PBP-GM24-XX					
		EM3A-20DLA2□□4			PDP-GA24-XX-II					
	EM3A-20DFB2□□4	PBP-GM24-XX								
EMG 2000r/min	1	EMG-10ALB2□□	PRONET-10AMG PRONET-10AEG-EC	Three-phase 200VAC	PDP-GA24-XX-II	PDM-GA14-XX- II (Without Brake) PDMB-GA14-XX- II (With Brake)	-			
		EMG-10AFD2□□			PBP-GM24-XX					
	1.5	EMG-15ALB2□□	PRONET-15AMG PRONET-15AEG-EC	Three-phase 200VAC	PDP-GA24-XX- II					
		EMG-15AFD2□□			PBP-GM24-XX					
	2	EMG-20ALB2□□	PRONET-20AMG PRONET-20AEG-EC	Three-phase 200VAC	PDP-GA24-XX- II					
		EMG-20AFD2□□			PBP-GM24-XX					
	3	EMG-30ALA2□□	PRONET-30AMG PRONET-30AEG-EC	Three-phase 400VAC	PDP-GA24-XX					
		EMG-30AFD2□□			PBP-GJ24-XX					
	5	EMG-50ALA2□□	PRONET-50AMG PRONET-50AEG-EC	Three-phase 400VAC	PDP-GA24-XX					
		EMG-50AFD2□□			PBP-GJ24-XX					
	1	EMG-10DLB2□□	PRONET-10DMG PRONET-10DEG-EC	Three-phase 200VAC	PDP-GA24-XX- II					
		EMG-10DFB2□□			PBP-GM24-XX					
1.5	EMG-15DLB2□□	PRONET-15DMG PRONET-15DEG-EC	Three-phase 400VAC	PDP-GA24-XX- II						
	EMG-15DFB2□□			PBP-GM24-XX						
2	EMG-20DLB2□□	PRONET-20DMG PRONET-20DEG-EC	Three-phase 400VAC	PDP-GA24-XX- II						
	EMG-20DFB2□□			PBP-GM24-XX						
3	EMG-30DLA2□□	PRONET-30DMG PRONET-30DEG-EC	Three-phase 400VAC	PDP-GA24-XX						
	EMG-30DFA2□□			PBP-GJ24-XX						
5	EMG-50DLA2□□	PRONET-50DMG PRONET-50DEG-EC	Three-phase 400VAC	PDP-GA24-XX						
	EMG-50DFA2□□			PBP-GJ24-XX						

Servo Motor	Power	Model	Servo Drive	Voltage	Encoder Cables	Power Cables	Brake Connector	
EML 1000r/min	1	EML-10ALB2□□	PRONET-10AMG PRONET-10AEG-EC	Three-phase 200VAC	PDP-GA24-XX- II	PDM-GA14-XX- II (Without Brake) PDMB-GA14-XX- II (With Brake)	-	
		EML-10AFD2□□			PBP-GM24-XX			
		EML-20ALA2□□			PDP-GA24-XX			
		EML-20AFD2□□			PBP-GJ24-XX			
	2	EML-30ALA2□□	PRONET-20AMG PRONET-20AEG-EC	Three-phase 200VAC	PDP-GA24-XX	PDM-GD12-XX(Without Brake)	EMG/EML/EMB Brake Connector	
		EML-30AFD2□□			PBP-GJ24-XX			
		EML-40ALA2□□			PDP-GA24-XX			
		EML-40AFD2□□			PBP-GJ24-XX			
EMB 1500r/min	1	EML-10DLB2□□	PRONET-10DMG PRONET-10DEG-EC	Three-phase 400VAC	PDP-GA24-XX- II	PDM-GA14-XX- II (Without Brake) PDMB-GA14-XX- II (With Brake)	-	
		EML-10DFB2□□			PBP-GM24-XX			
		EML-20DLA2□□			PDP-GA24-XX			
		EML-20DFA2□□			PBP-GJ24-XX			
	2	EML-30DLA2□□	PRONET-30DMG PRONET-30DEG-EC	Three-phase 400VAC	PDP-GA24-XX	PDM-GD12-XX(Without Brake)	EMG/EML/EMB Brake Connector	
		EML-30DFA2□□			PBP-GJ24-XX			
		EML-40DLA2□□			PDP-GA24-XX			
		EML-40DFA2□□			PBP-GJ24-XX			
EMB 1500r/min	7.5	EMB-75DSA2□□	PRONET-70DMA PRONET-70DEA-EC	Three-phase 400VAC	PDP-GA24-XX	-	EMG/EML/EMB Brake Connector	
		EMB-75DSA2□□						PRONET-75DMA
	11	EMB-1ADSA2□□	PRONET-1ADM PRONET-1ADEA-EC		Three-phase 400VAC	PRP-BA24-XX	-	EMG/EML/EMB Brake Connector
		EMB-1EDSA2□□						
	15	EMB-1EDSA2□□	PRONET-1EDEM PRONET-1EDEA-EC		Three-phase 400VAC	PRP-BA24-XX	-	EMG/EML/EMB Brake Connector
		EMB-1EDSA2□□						
	22	EMB-2BDSA22	PRONET-2BDM PRONET-2BDEA-EC		Three-phase 400VAC	PRP-BA24-XX	-	EMG/EML/EMB Brake Connector
		EMB-2BDSA22						
	7.5	EMB-75DRA2□□	PRONET-70DMB PRONET-75DMB		Three-phase 400VAC	PRP-BA24-XX	-	EMG/EML/EMB Brake Connector
		EMB-75DRA2□□						
11	EMB-1ADRA2□□	PRONET-1ADM PRONET-1EDMB	Three-phase 400VAC	PRP-BA24-XX	-	EMG/EML/EMB Brake Connector		
	EMB-1EDRA2□□						PRONET-1EDMB	
15	EMB-1EDRA2□□	PRONET-1EDMB PRONET-1EDMB	Three-phase 400VAC	PRP-BA24-XX	-	EMG/EML/EMB Brake Connector		
	EMB-1EDRA2□□						PRONET-1EDMB	
22	EMB-2BDR22	PRONET-2BDM PRONET-2BDMB	Three-phase 400VAC	PRP-BA24-XX	-	EMG/EML/EMB Brake Connector		
	EMB-2BDR22						PRONET-2BDMB	

Note :

- : The first is option of brake and oil seal, the second is the option of type of plug.
- XX : Cable length(1M5,03,05,08,10,12,15,20), the unit is meter.Providing flexible cables, marked with suffix "-RX".
- For EMJ series motor, the brake cable is separated with power cable, we provide the plug for clients.
- I/O Connector Standard: 50 Pins EC bus: 20 Pins.
- Debug Cables
Standard:USB-RS485(RJ45)
EC BUS: MINI USB-Double Shielded magnetic rings-1M5.
- Diameter recommend of self-made power Cables:
0.05~1kW motor:1mm²;1-2kW motor:2mm²;2-5kW motor:4mm²;7.5kW motor:3.27mm²;
11kW motor:5.09mm²; 15kW motor:6.9mm² ;22kW motor:9.5mm².

02

SERVO DRIVE



Part Number

ProNet - 10 A E G - EC

ProNet Servo Drive Rated Power Power Voltage Control Style Encoder Interface Extended Module

Sign	Spec.	Sign	Spec.	Sign	Spec.	Sign	Spec.	Sign	Spec.
A5:	0.05kW	A:	200VAC	M:	Pulse	G:	17 Bits/20 Bits/23 Bits	-EC:	EtherCAT
01:	0.1kW	D:	400VAC	CANopen		Serial Encoder	(self-adaption)	None:	M control
02:	0.2kW			E:	EtherCAT			Style	
04:	0.4kW					A:	17 Bits Serial Encoder		
08:	0.75kW					B:	Resolver		
10:	1.0kW								
15:	1.5kW								
20:	2.0kW								
30:	3.0kW								
50:	5.0kW								
70:	7.0kW								
75:	7.5kW								
1A:	11kW								
1E:	15kW								
2B:	22kW								

Ratings

Servo Drive Model: ProNet-	A5A	01A	02A	04A	08A	10A	15A	20A	30A	50A	10D	15D	20D	30D	50D	70D	75D	1AD	1ED	2BD
Applicable Servomotor :EM3A-	A5A	01A	02A	04A	08A	10A	15A	20A	-	-	-	15D	20D	-	-	-	-	-	-	-
Applicable Servomotor : EMJ-	-	-	02A	04A	08A	10A	-	-	-	-	-	-	-	-	-	-	-	-	-	-
Applicable Servomotor : EMG-	-	-	-	-	-	10A	15A	20A	30A	50A	10D	15D	20D	30D	50D	-	-	-	-	-
Applicable Servomotor : EML-	-	-	-	-	-	10A	-	20A	30A	40A	10D	-	20A	30A	40A	-	-	-	-	-
Applicable Servomotor : EMB-	-	-	-	-	-	-	-	-	-	-	-	-	-	-	-	75D	75D	1AD	1E D	2BD
Continuous Output Current[Arms]	0.9	1.1	1.8	3.3	5.1	6.9	9.3	12.0	18.0	28.0	3.2	5.0	6.4	9.0	18.0	18.0	18.0	28.0	38.0	55.0
Max. Output Current [Arms]	3.3	4.0	5.4	9.9	17.0	17.0	28.0	36.0	54.0	64.0	9.6	15.0	19.2	27.0	49.5	49.5	49.5	84.0	84.5	134.0
Main Input Power Supply Capacity [kVA]	0.2	0.3	0.5	0.9	1.3	1.8	2.5	3.5	4.5	7.5	1.8	2.8	3.5	5.0	8.2	12.0	12.0	18.0	22.0	32.0
DC24V Power Supply Capacity [W]	-	-	-	-	-	-	-	-	-	-	30.0	30.0	30.0	45.0	45.0	45.0	-	-	-	-

Specification

Items		Specification	
Input Power Supply	Main Circuit	200V	Single-Phase 200 ~ 230VAC (0.05kW~0.4kW)
		400V	Three-phase 200 ~ 230VAC (0.75kW~5.0kW)
	Control Circuit	200V	Three-phase 380 ~ 440VAC (1kW~5.0kW)
		400V	Single-Phase 200 ~ 230VAC (0.05kW~5kW) 24VDC (1kW~5.0kW)
Control Method		SVPWM Control	
Feedback		17bit Absolute encoder : 131072P/R 20bit incremental encoder:1048576 P/R 23bit Absolute encoder : 8388608P/R Resolver	
Operating Conditions	Ambient/Storage Temperature		Ambient temperature: 0~+55℃ Storage temperature: -25~+85℃
	Ambient/Storage Humidity		5% ~ 95% RH (no condensation)
	Elevation		1000m or less
	Vibration/Shock Resistance		Vibration Resistance : 4.9m/s ² Impact Resistance : 19.6m/s ²
Configuration		Base-mounted	
Performance	Speed Control Range		1:5000
	Speed Regulation	Load Regulation	0 ~ 100% load : ±0.01% or less (at rated speed)
		Voltage Regulation	Rated voltage ±10%: 0% (at rated speed)
Temperature Regulation		25±25℃ : ±0.1% or less (at rated speed)	
Torque Control	Analog Reference Input	Reference Voltage	±10VDC at rated torque (Variable setting range:±0 ~ 10VDC) Max. input voltage: ±12V
		Input Impedance	About 10M or above
		Circuit Time Constant	10μs
Speed Control	Analog Input	Reference Voltage	±10VDC at rated speed (Variable setting range:±0 ~ 10VDC) Max. input voltage: ±12V
		Input Impedance	About 10M or above
		Circuit Time Constant	10μs
	Speed Selection	Rotation Direction Selection	With /P-CON signal
		Speed Selection	Speed 1 to 7
	Function	Soft Start Setting	0 ~ 10s (Can be set individually for acceleration and deceleration)
Position Control	Pulse Reference	Type	Sign + pulse train;CCW + CW pulse train; 90°phase difference 2-phase (phase A + phase B)
		Form	Non-insulated linde driver (about + 5V), open collector
	Position Reference	Frequency	×1 multiplier : 4Mpps ×2 multiplier : 2Mpps ×4 multiplier : 1Mpps Open collector : 200Kpps Frequencies drop when the duty ratio error occurs
		Position Setting	16 postion nodes can be set

Items		Specifications	
I/O Signals	Encoder Dividing Pulses Output	Phase-A, phase-B, phase-C: line driver output Number of dividing pulses: Any setting ratio is available	
	Sequence Input	Number of channels	Standard: 8 channels EC BUS: 5 channels
		Function	Signal allocations and positive/negative logic modifications: Servo ON (S-ON), P control (P-CON), alarm reset (ALM-RST), position error clear (CLR), forward run prohibited (P-OT), reverse run prohibited (N-OT), forward current limit (P-CL), reverse current limit (N-CL) and so on.
	Sequence Output	Number of channels	Standard: 4 channels EC BUS: 3 channels
Function		Signal allocations and positive/negative logic modifications: Positioning completion (COIN), speed coincidence (V-CMP), servomotor rotation detection (TGON), servo ready (S-RDY), torque limit output (CLT), brake interlock output (BK), encoder C pulse (PGC) and Over travel signal (OT).	
Regenerative Processing Functions		0.75kW~7.5kW: built-in regenerative resistor; 11kW~22kW: external regenerative resistor	
Protection Functions		Overcurrent, overvoltage, low voltage, overload, regeneration error, overspeed, etc	
Utility Function		Alarm trace back, JOG operation, load inertia detection, etc	
Display Function		CHARGE (Red), POWER (Green), 7-segment LEDs x 5 (Built-in digital panel operator)	
Communication Function		RS-485 communication port, MODBUS protocol; CAN communication port, CANopen protocol; EtherCAT communication module, CiA402 protocol	

Servo Drive Size

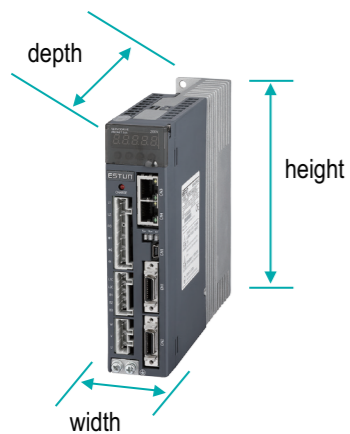

Power (kW)	200V		400V	
	W	HxD (mm)	W	HxD (mm)
0.05	40	160X180	—	—
0.1	40	160X180	—	—
0.2	40	160X180	—	—
0.4	40	160X180	—	—
0.75	84	186X180	—	—
1.0	84	186X180	100	186X180
1.5	100	186X180	100	186X180
2.0	100	186X180	100	186X180
3.0	125	271X205	125	271X205
5.0	125	271X205	125	271X205
7.0	—	—	125	271X205
7.5	—	—	186	462x168
11	—	—	186	462x168
15	—	—	186	462x168
22	—	—	186	462x168

03 SERVO MOTOR



Part Number

Model	Rated Output Power	Voltage	Encoder	Designing Sequence	Shaft End	Option Parts	Connector Types
EM3A - 02 A F A 2 1 1							
Sign. Spec.	Sign. Spec.	Sign. Spec.	Sign. Spec.	Sign. Spec.	Sign. Spec.	Sign. Spec.	Sign. Spec.
A5: 0.05kW 01: 0.1kW 02: 0.2kW 04: 0.4kW 08: 0.75kW 10: 1kW 15: 1.5kW 20: 2kW	A: 200VAC D: 400VAC	F: 20-bit Incremental Encoder L: 23-bit Absolute Encoder	A: Designing Sequence	1: Straight Without Key 2: Straight With Key, screw Thread (Standard)	1: None 2: With Oil Seal 3: With Brake (DC24V) 4: With Oil Seal, With Brake (DC24V)	1: Lead Wire Without Waterproof 2: Lead Wire With Waterproof 3: Connector 4: Aviation Plug	

Model	Rated Output Power	Voltage	Encoder	Designing Sequence	Shaft End	Option Parts
EMG - 10 A F D 2 1						
Sign. Spec.	Sign. Spec.	Sign. Spec.	Sign. Spec.	Sign. Spec.	Sign. Spec.	Sign. Spec.
J: EMJ Series G: EMG Series L: EML Series B: EMB Series	02: 0.2kW 04: 0.4kW 08: 0.75kW 10: 1.0kW 15: 1.5kW 20: 2.0kW 30: 3.0kW 50: 5.0kW 70: 7.0kW 75: 7.5kW 1A: 11kW 1E: 15kW 2B: 22kW	A: 200VAC D: 400VAC	F: 20-bit Incremental Encoder S: 17-bit Absolute Encoder L: 23-bit Absolute Encoder R: Resolver	A, B, D, H, M: Designing Sequence	1: Straight Without Key 2: Straight With Key, screw Thread (Standard)	1: None 2: With Oil Seal 3: With Brake (DC24V) 4: With Oil Seal, With Brake (DC24V)



EM3A Servo Motor Specifications

Voltage		200VAC									
Servo Motor model		EM3A-									
		ASFA2□□1 ASALA2□□1	01AFA2□□1 01ALA2□□1	02AFA□□□1 02ALA□□□1	04AFA□□□1 04ALA□□□1	08AFA□□□1 08ALA□□□1	10AFA□□□1 10ALA□□□1	15AFA2□□4 15ALA2□□4	15DFA2□□4 15DLA2□□4	20AFA2□□4 20ALA2□□4	20DFA2□□4 20DLA2□□4
Rated Output	kW	0.05	0.1	0.2	0.4	0.75	1	1.5	1.5	2.0	2.0
Rated Torque	N·m	0.159	0.318	0.637	1.27	2.39	3.18	4.78	4.78	6.37	6.37
Instantaneous Peak Torque	N·m	0.557	1.11	1.91	3.82	7.16	8.8	14.3	14.3	19.1	19.1
Rated Current	Arms	0.9	1.1	1.5	2.9	5.1	6.9	9.0	4.5	12.0	6.0
Instantaneous Max current	Arms	3.3	4	4.7	9.2	16.1	19.5	30	15	39	20
Rated Speed	r/min	3000									
Max. Speed	r/min	6000					5000				
Rotor Moment of Inertia	×10 ⁻⁴ kg·m ²	0.023 (0.0268)	0.0428 (0.0465)	0.147 (0.179)	0.244 (0.276)	0.909 (1.07)	1.14 (1.30)	2.24 (2.44)		2.84 (3.04)	
Weight	kg	0.368 (0.588)	0.491 (0.696)	0.9 (1.3)	1.3 (1.7)	2.6 (3.2)	3.1 (3.8)	5.7 (7.0)		6.6 (8.1)	
Brake Rated Voltage		DC24V±10%									
Brake Rated Power	W	4.0		7.4		9.6		17.6			
Brake Rated Torque	N·m	0.32		1.5		3.2		8.0			
Encoder		20-bit Incremental Encoder 1048576 P/R; 23-bit Absolute Encoder 8388608P/R									
Insulation Class		F									
Ambient Temperature		0 ~ +40°C (No freezing)									
Ambient Humidity		20%~85% RH(No condensing)					20%~80% RH(No condensing)				
Vibration		Vibration: Dynamic 49m/s ² (5G) ; Static 24.5m/s ² ; Shock: 98m/s ² (10G)									
Enclosure		Totally Enclosed,Self-cooled,IP65(Except for shaft opening,when not equipped with oil seal;Except for connector,when not equipped with waterproof plug)									

Note:The data inside parenthesis represents the values with brake.

EMJ Servo Motor Specifications

Voltage		200VAC				
Servo Motor model		EMJ-				
		02ASA□□ 02AFD□□	04ASA□□ 04AFD□□	04ASH□□ 04AFM□□	08ASB□□ 08AFD□□	10ASB□□ 10AFD□□
Rated Output	kW	0.2		0.4		1.0
Rated Torque	N·m	0.64		1.27		3.18
Instantaneous Peak Torque	N·m	1.91		3.82		9.55
Rated Current	Arms	1.4		2.8		5.3
Instantaneous Max current	Arms	4.2		8.4		15.9
Rated Speed	r/min	3000				
Max. Speed	r/min	4500				
Rotor Moment of Inertia	×10 ⁻⁴ kg·m ²	0.19 (0.23)	0.31 (0.35)	0.7 (0.74)	1.35 (1.47)	1.74 (1.87)
Weight	kg	1.21 (1.71)	1.52 (2.02)	1.52 (2.17)	2.96 (3.66)	3.69 (4.29)
Brake Rated Voltage		DC24V±10%				
Brake Rated Power	W	7.2			11.5	
Brake Rated Torque	N·m	1.3			3.2	
Encoder		17-bit Absolute encoder		20-bit Incremental Encoder 1048576 P/R		
Insulation Class		F				
Ambient Temperature		0 ~ +40°C (No freezing)				
Ambient Humidity		20%~80% RH(No condensing)				
Vibration		49m/s ²				
Enclosure		Totally Enclosed,Self-cooled,IP65(Except for shaft opening,when not equipped with oil seal)				

Note:The data inside parenthesis represents the values with brake.

EMG Servo Motor Specifications

Voltage		200VAC / 400VAC									
Servo Motor model		EMG-									
		10AFD□□ 10ALB□□	10DFB□□ 10DLB□□	15AFD□□ 15ALB□□	15DFB□□ 15DLB□□	20AFD□□ 20ALB□□	20DFB□□ 20DLB□□	30AFD□□ 30ALA□□	30DFA□□ 30DLA□□	50AFD□□ 50ALA□□	50DFA□□ 50DLA□□
Rated Output	kW	1.0	1.0	1.5	1.5	2.0	2.0	3.0	3.0	5.0	5.0
Rated Torque	N·m	4.78	4.78	7.16	7.16	9.55	9.55	14.3	14.3	23.9	23.9
Instantaneous Peak Torque	N·m	14.3	14.3	21.5	21.5	28.7	28.7	43.0	43.0	76.0	76.0
Rated Current	Arms	5.8	3.0	8.2	4.3	11.3	5.7	18.0	8.8	28.0	15.0
Instantaneous Max current	Arms	17.4	9.0	24.6	12.9	33.9	17.1	54.0	26.4	84.0	45.0
Rated Speed	r/min	2000									
Max. Speed	r/min	3000									
Rotor Moment of Inertia	×10 ⁻⁴ kg·m ²	13.2 (14.3)		18.4 (19.5)		23.5 (24.6)		41.3 (44.5)		65.7 (68.9)	
Weight	kg	7 (8.5)		8.9 (10.4)		10.8 (12.3)		16.63 (20.23)		24.3 (27.9)	
Brake Rated Voltage		DC24V±10%									
Brake Rated Power	W	19.5					35				
Brake Rated Torque	N·m	12					40				
Encoder		20-bit Incremental Encoder; 23-bit Absolute Encoder									
Insulation Class		F									
Ambient Temperature		0 ~ +40°C (No freezing)									
Ambient Humidity		20%~80% RH(Non-condensing)									
Vibration		24.5m/s ²									
Enclosure		Totally Enclosed,Self-cooled,IP65(Except for shaft opening,when not equipped with oil seal)									

Note:The data inside parenthesis represents the values with brake.

EML Servo Motor Specifications

Voltage		200VAC / 400VAC									
Servo Motor model		EML-									
		10AFD□□ 10ALB□□	10DFB□□ 10DLB□□	20AFD□□ 20ALA□□	20DFA□□ 20DLA□□	30AFD□□ 30ALA□□	30DFA□□ 30DLA□□	40AFD□□ 40ALA□□	40DFA□□ 40DLA□□		
Rated Output	kW	1.0		2.0		3.0		4.0			
Rated Torque	N·m	9.55		19.1		28.7		38.2			
Instantaneous Peak Torque	N·m	28.7		57.3		86.0		114.6			
Rated Current	Arms	5.5	2.8	12.0	6.2	18.0	9.0	24.0	12.2		
Instantaneous Max current	Arms	16.5	8.4	36.0	18.6	54.0	27.0	72.0	36.6		
Rated Speed	r/min	1000									
Max. Speed	r/min	1500									
Rotor Moment of Inertia	×10 ⁻⁴ kg·m ²	23.5 (24.6)		53.5 (56.7)		77.8 (81.0)		102.2 (105.4)			
Weight	kg	10.8 (12.3)		18.1 (21.7)		19.5 (23.1)		34.75 (38.35)			
Brake Rated Voltage		DC24V±10%									
Brake Rated Power	W	19.5					35				
Brake Rated Torque	N·m	12					40				
Encoder		20-bit Incremental Encoder; 23-bit Absolute Encoder									
Insulation Class		F									
Ambient Temperature		0 ~ +40°C (No freezing)									
Ambient Humidity		20%~80% RH(Non-condensing)									
Vibration		24.5m/s ²									
Enclosure		Totally Enclosed,Self-cooled,IP65(Except for shaft opening,when not equipped with oil seal)									

Note:The data inside parenthesis represents the values with brake.

EMB Servo Motor Specifications

Voltage		200VAC / 400VAC			
Servo Motor model	EMB-	75D□□□□	1AD□□□□	1ED□□□□	2BD□□□□□
Rated Output	kW	7.5	11.0	15.0	22.0
Rated Torque	N·m	47.8	70.0	95.5	140.0
Instantaneous Peak Torque	N·m	143.4	175	191	350
Rated Current	Arms	18.0	28.0	38.0	52.0
Instantaneous Max current	Arms	56.0	70.0	84.0	130
Rated Speed	r/min	1500			
Max. Speed	r/min	2000			
Rotor Moment of Inertia	$\times 10^{-4} \text{kg} \cdot \text{m}^2$	186.2 (193.6)	271.6 (278.9)	338.8 (346.1)	576.62 (601.62)
Weight	kg	43.8 (49.8)	54.66 (60.66)	63.07 (69)	
Brake Rated Voltage		DC24V \pm 10%			
Brake Rated Power	W	90			
Brake Rated Torque	N·m	100			150
Encoder		17-bit Absolute Encoder; Resolver			
Insulation Class		F			
Ambient Temperature		0 ~ +40°C(No freezing)			
Ambient Humidity		20%~80% RH(Non-condensing)			
Vibration		24.5m/s ²			
Enclosure		Totally Enclosed,Self-cooled,IP65(Except for shaft opening,when not equipped with oil seal) Fan :IP20			

Note:The data inside parenthesis represents the values with brake.

EM3A-	L	LL	Flange Side								S	Tap×Depth	Key				
			LR	LE	LF	LC	LA	LB	LZ	QK			W	T	U	Q	
A5ALA	87.5 (121)	62.5 (96)	25	2.5	5	40	46	30	4.3	8	M3X6	14	3	3	1.8	22.5	
01ALA	103.5 (137)	78.5 (112)	25	2.5	5	40	46	30	4.3	8	M3X6	14	3	3	1.8	22.5	
02ALA	108 (137)	78 (107)	30	3	7	60	70	50	5.5	14	M5X12	20	5	5	3	27	
04ALA	129 (158)	99 (128)	30	3	7	60	70	50	5.5	14	M5X12	20	5	5	3	27	
08ALA	151(184)	111(144)	40	3	8	80	90	70	6.6	19	M6X12	25	6	6	3.5	37	
10ALA	165(198)	125(158)	40	3	8	80	90	70	6.6	19	M6X12	25	6	6	3.5	37	
02AFA	126.5(155.5)	96.5(125.5)	30	3	7	60	70	50	5.5	14	M5X12	20	5	5	3	27	
04AFA	147.5(176.5)	117.5 (146.5)	30	3	7	60	70	50	5.5	14	M5X12	20	5	5	3	27	
08AFA	167.5(184)	127.5 (144)	40	3	8	80	90	70	6.6	19	M6X12	25	6	6	3.5	37	
10AFA	182.5(214.5)	142.5 (174.5)	40	3	8	80	90	70	6.6	19	M6X12	25	6	6	3.5	37	
15AFA	235 (272)	190 (227)	45	3	10	100	115	95	7	24	M8X16	32	8	5	3	40	
15ALA			45	3	10	100	115	95	7	24	M8X16	32	8	5	3	40	
15DFA			45	3	10	100	115	95	7	24	M8X16	32	8	6	3.5	40	
15DLA			45	3	10	100	115	95	7	24	M8X16	32	8	6	3.5	40	
20AFA			45	3	10	100	115	95	7	24	M8X16	32	8	5	3	40	
20ALA	255(292)	210(247)	45	3	10	100	115	95	7	24	M8X16	32	8	5	3	40	
20DFA			45	3	10	100	115	95	7	24	M8X16	32	8	6	3.5	40	
20DLA			45	3	10	100	115	95	7	24	M8X16	32	8	6	3.5	40	

Note:The data inside parenthesis represents the values with brake.

EM3A Dimension

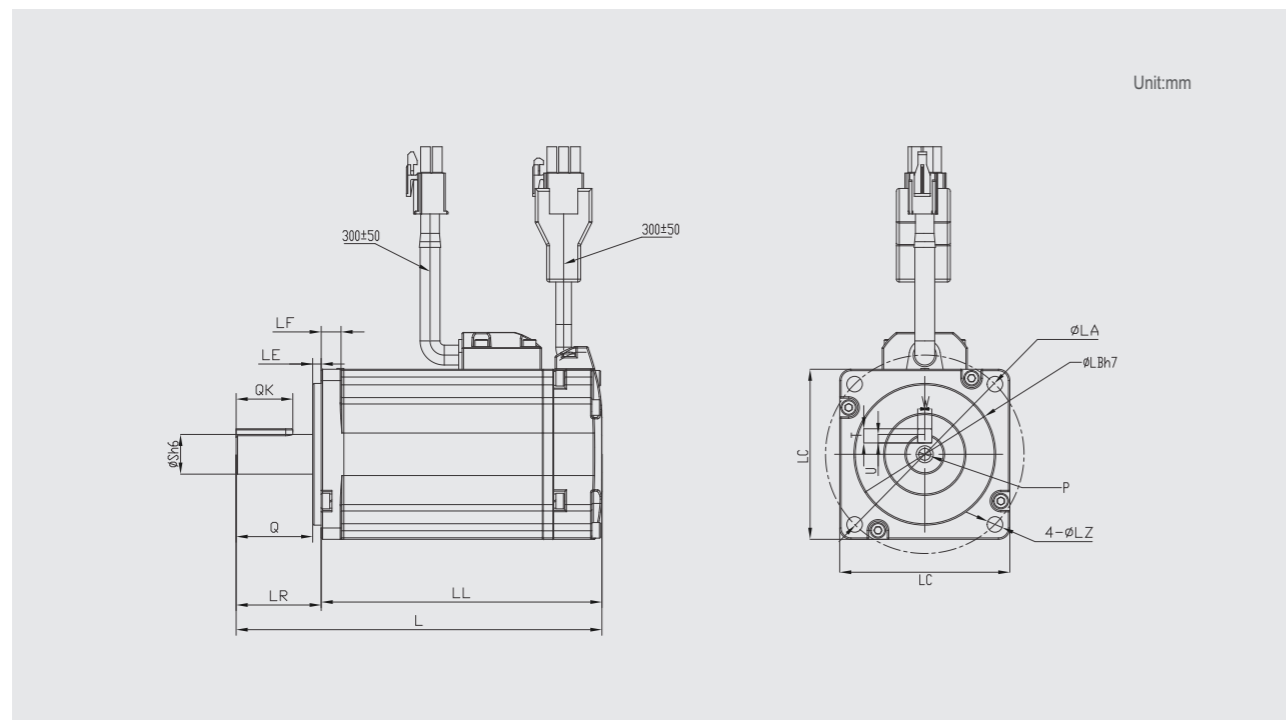

EM3A Torque-Speed Features

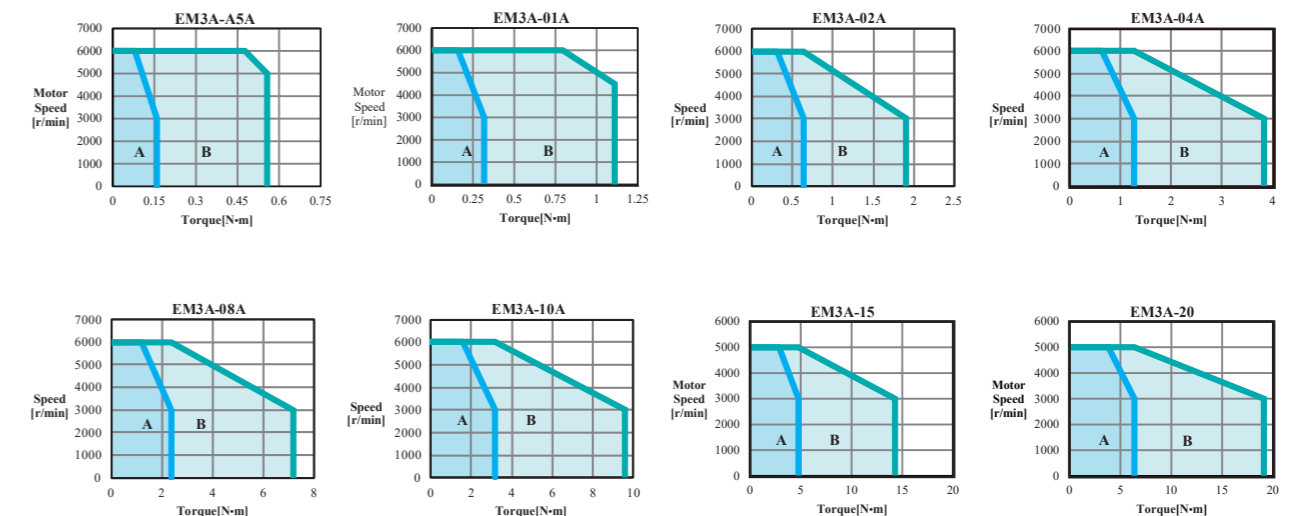

A:Continuous Working Area B:Repeatedly Working Area

EMJ Dimension

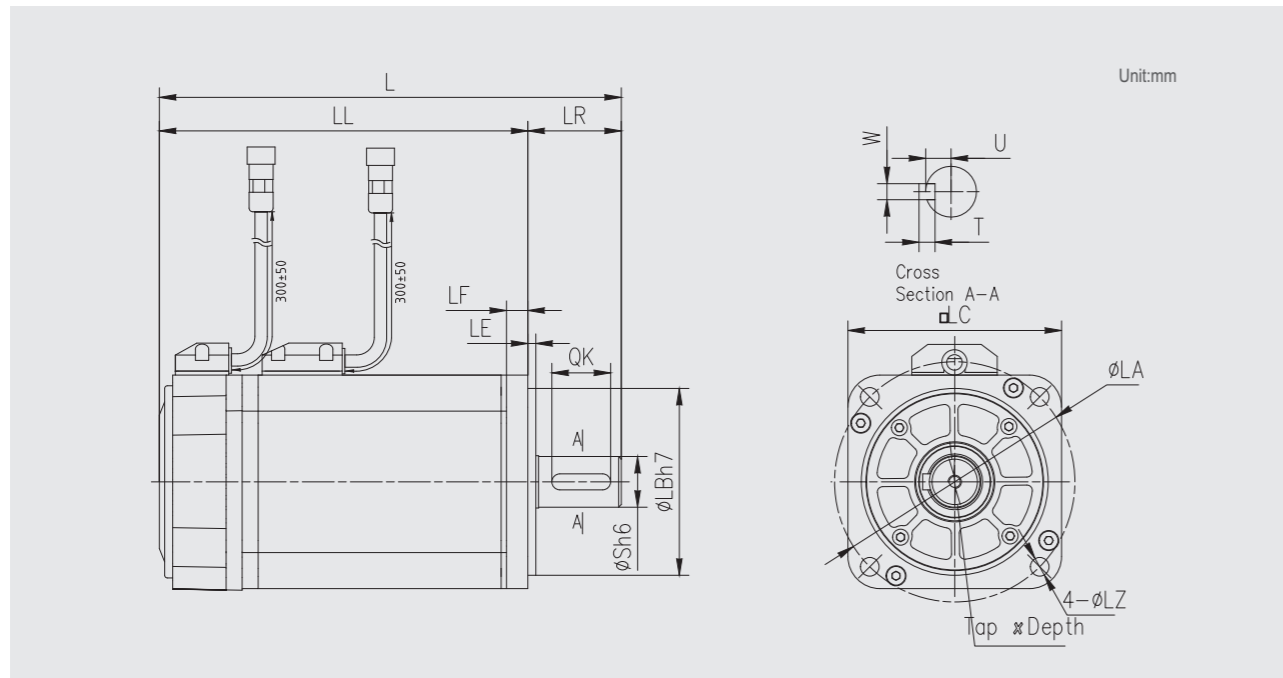

EMJ-	L	LL	Flange Side							S	Tap×Depth	Key															
			LR	LE	LF	LC	LA	LB	LZ			QK	QL	W	T	U											
02AFD	142(182)	112(152)	30	3	6	60	70	50	5.5	14	M5×10	16	5	5	3												
02ASA	154(194)	124(164)																									
04AFD	161(201)	131(171)																									
04ASA	174(214)	144(184)																									
04AFM	172(212)	142(182)																									
04ASH	182(222)	152(192)																									
08AFD	173(216)	138(181)														35	9	80	90	70	7	19	M6×15	22	6	6	3.5
08ASB	186(229)	151(194)																									
10AFD	191(234)	156(199)																									
10ASB	204(247)	169(212)																									

Note: Numbers inside parentheses represents the values with brake.

EMJ Torque-Speed Features

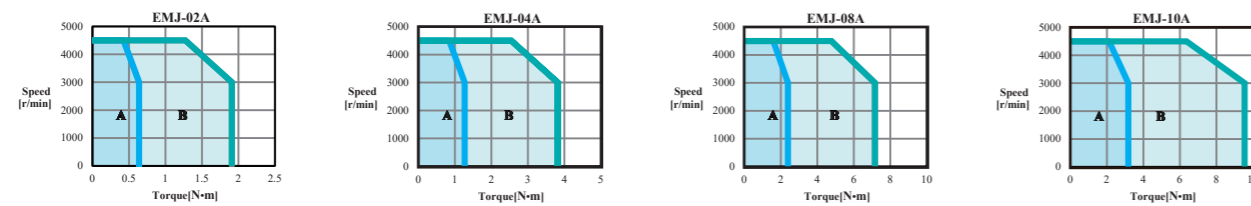

A: Continuous Working Area B: Repeatedly Working Area

EMG Dimension

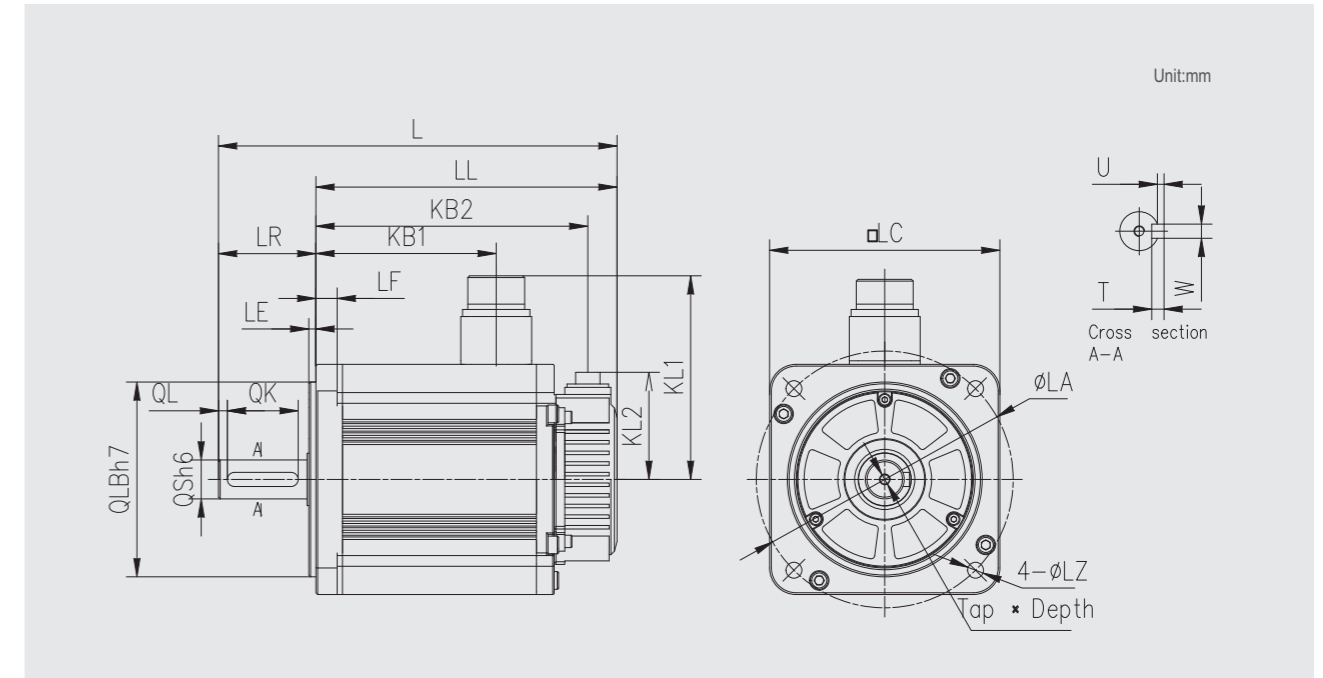

EMG-	L	LL	KB1	KB2	KL1	KL2	Flange Side							S	Tap×Depth	Key				
							LR	LE	LF	LC	LA	LB	LZ			QK	QL	W	T	U
10□□B/D	203 (245.5)	148 (190.5)	80 (103.2)	131.5 (174)	117	60.5	55	4	12	130	145	110	9	22	M6×20	40	5	8	7	4
15□□B/D	225 (267.5)	170 (212.5)	102 (125.2)	153.5 (196)																
20□□B/D	247 (289.5)	192 (234.5)	124 (147.2)	175.5 (218)																
30□□A/D	307 (378)	228 (299)	143	203 (274)	140	79	79	3.2	18	180	200	114.3	13.5	35	M8×16	55	6	10	8	5
50□□A/D	357 (428)	278 (349)	183	253 (324)																

Note: Numbers inside parentheses represents the values with brake.

EMG Torque-Speed Features

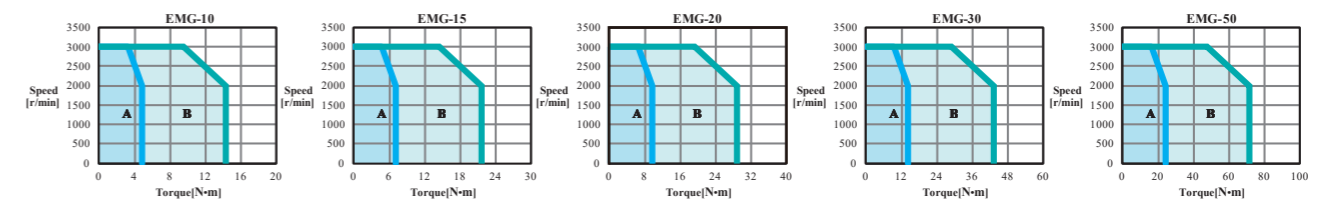

A: Continuous Working Area B: Repeatedly Working Area

EML Dimension

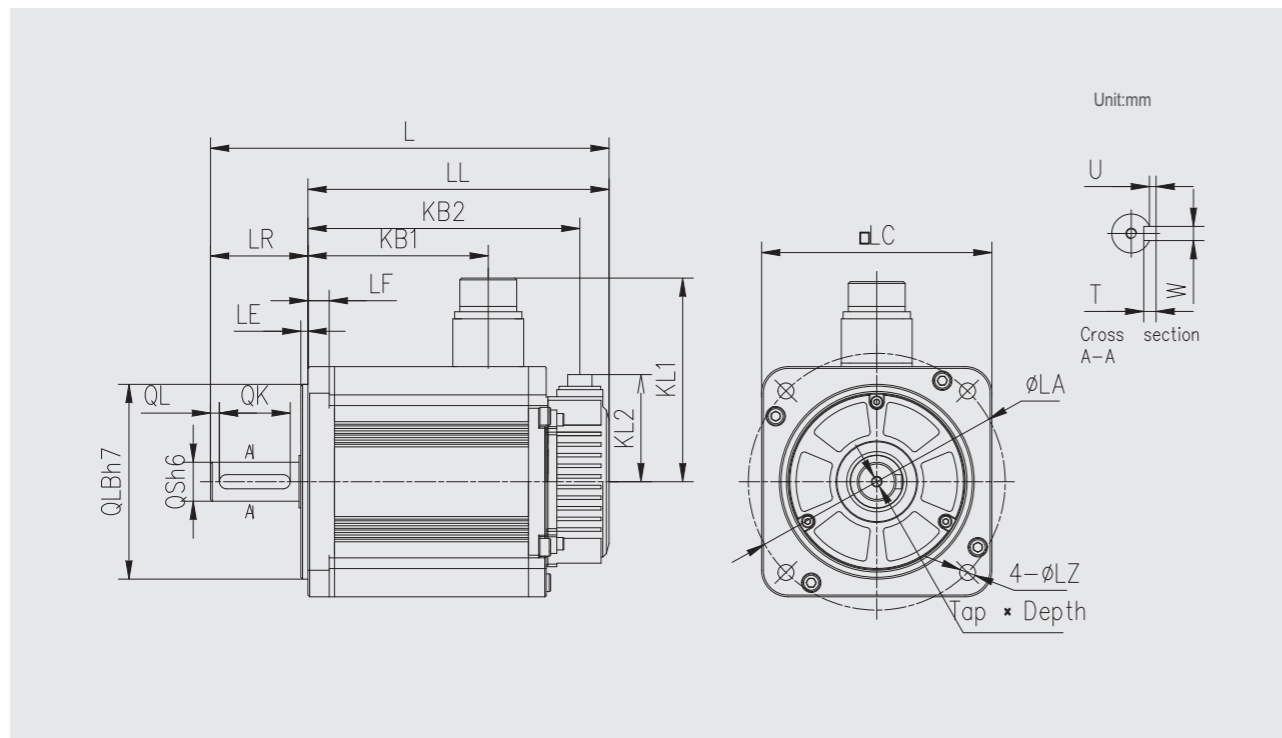

EML-	L	LL	KB1	KB2	KL1	KL2	Flange Side							S	Tap×Depth	Key				
							LR	LE	LF	LC	LA	LB	LZ			QK	QL	W	T	U
10□□B/D	247 (289.5)	192 (234.5)	124 (147.2)	175.5 (218)	117	60.5	55	4	12	130	145	110	9	22	M6×20	40	5	8	7	4
20□□A/D	332 (401)	253 (322)	168	228 (245)	140	79	79	3.2	18	180	200	114.3	13.5	35	M8×16	55	6	10	8	5
30□□A/D	372 (443)	293 (364)	208	268 (287)																
40□□A/D	412 (478)	333 (399)	243	308 (322)																

Note: Numbers inside parentheses represents the values with brake.

EML Torque-Speed Features

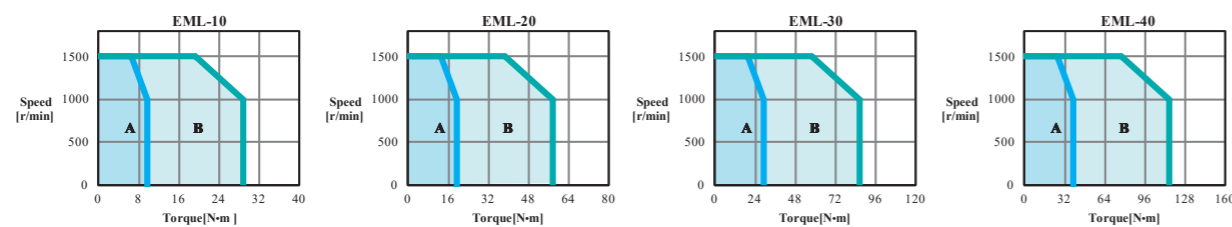

A: Continuous Working Area B: Repeatedly Working Area

EMB Dimension

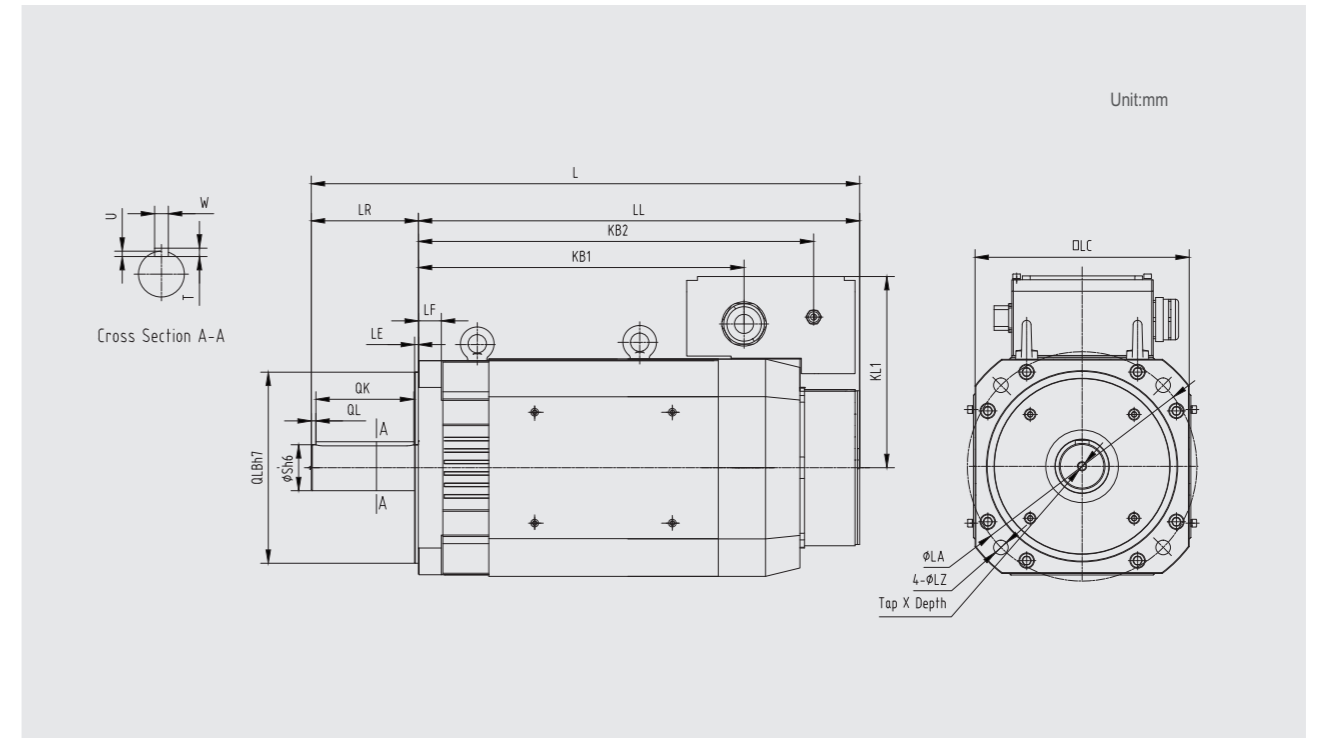

EMB-	L	LL	KB1	KB2	KL1	Flange Side							S	Tap×Depth	Key				
						LR	LE	LF	LC	LA	LB	LZ			QK	QL	W	T	U
75D□□	530 (625)	414 (509)	366 (461)	302 (397)	184	116	4	20	220	235	200	13.5	42	M16×32	90	6	12	8	5
1AD□□	580 (675)	464 (559)	416 (511)	352 (447)															
1ED□□	615 (710)	499 (594)	451 (546)	387 (482)															
2BD□□	717 (792.5)	577 (652.5)	432 (495.5)	523 (586.5)	250	140	5	30	280	300	250	19	60	M12×25	128	6	18	11	7

Note: Numbers inside parentheses represents the values with brake.

EMB Torque-Speed Features

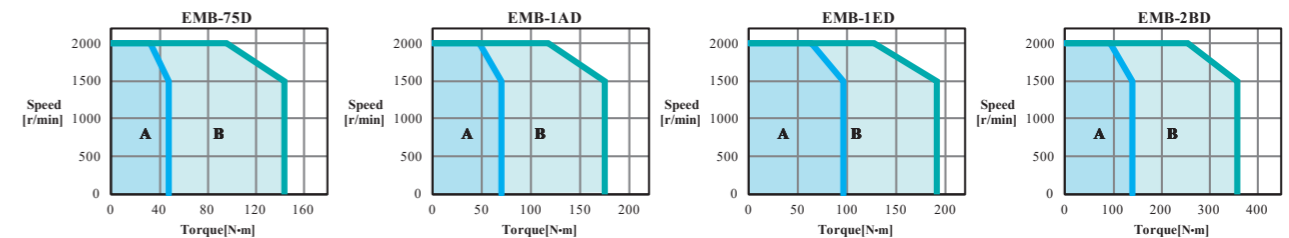

A: Continuous Working Area B: Repeatedly Working Area

04 WIRING

Wiring

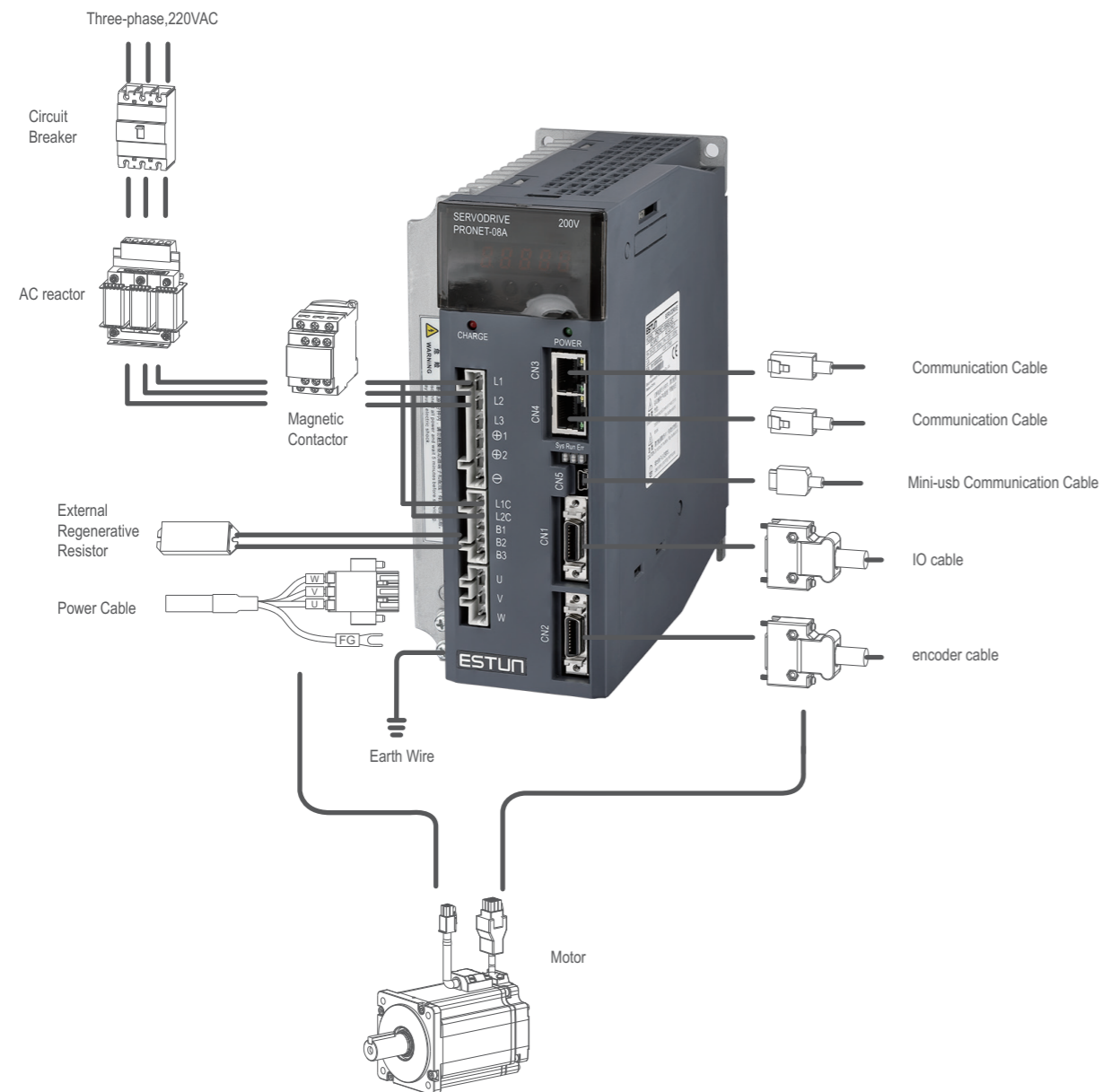

05 ACCESSORIES

Cables

Power Cables

PDM-JB18-XX

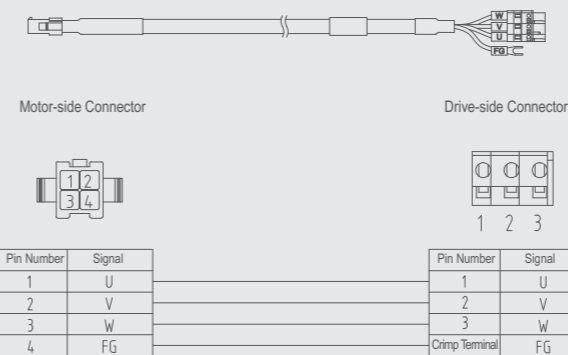

PDMB-JB18-XX

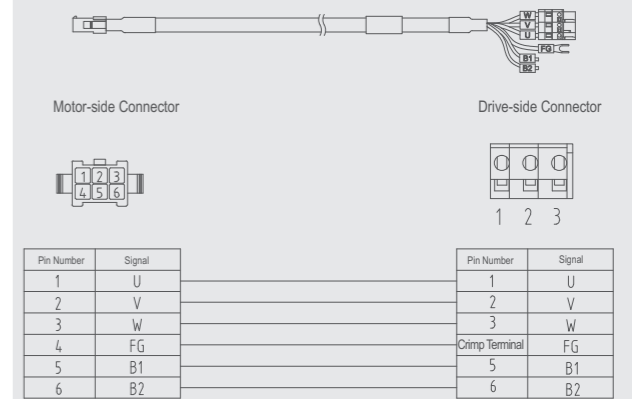

PDM-GA14-XX- II

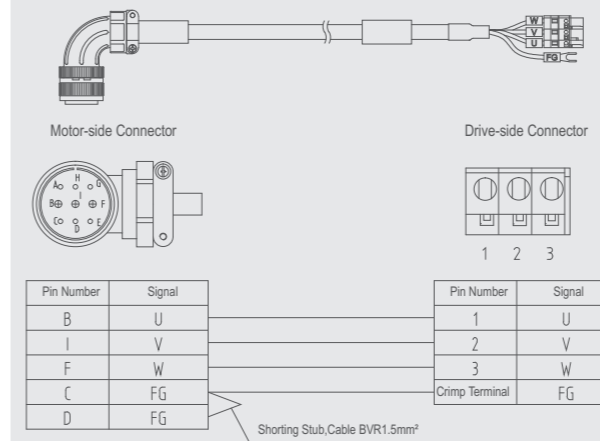

PDMB-GA14-XX- II

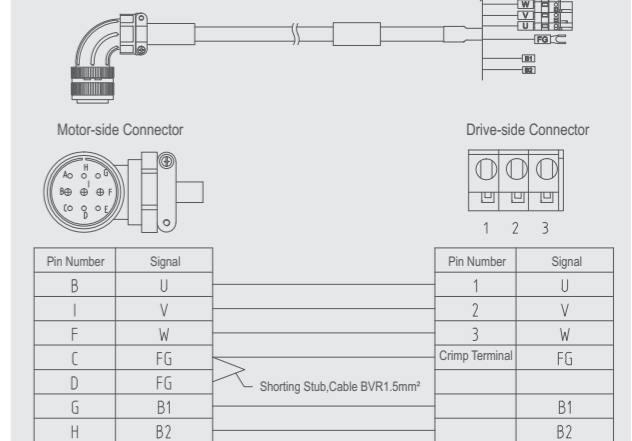

Encoder Cables

PDM-GD14-XX

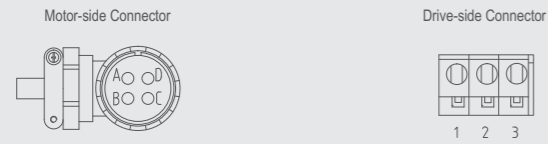
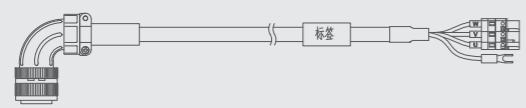

Pin Number	Signal	Pin Number	Signal
A	U	1	U
B	V	2	V
C	W	3	W
D	FG	Crimp Terminal	FG

PDM-GD12-XX

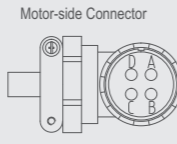
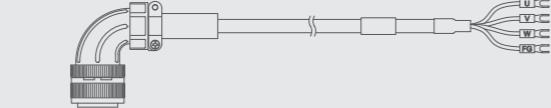

Pin Number	Signal	Pin Number	Signal
A	U	1	U
B	V	2	V
C	W	3	W
D	FG	Crimp Terminal	FG

PBP-JB24-XX

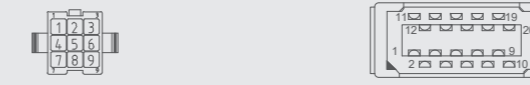
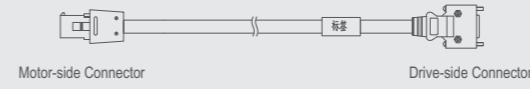

Pin Number	Signal	Pin Number	Signal
1/Ø	S+	7	S+
2/Ø	S-	8	S-
3	-	17	-
4/Ø	MA+	5	MA+
5/Ø	MA-	6	MA-
6/Ø	PG5V	9	PG5V
7/Ø	PG0V	19	PG0V
8	-	18	-
9/Ø	FG	Shell	FG

PDP-JB24-XX

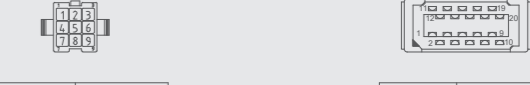
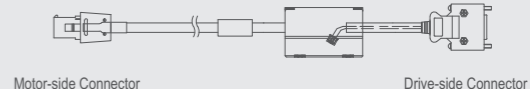

Pin Number	Signal	Pin Number	Signal
1/Ø	S+	7	S+
2/Ø	S-	8	S-
3/Ø	BAT+	17	BAT+
4	-	4	-
5	-	5	-
6/Ø	PG5V	9	PG5V
7/Ø	PG0V	19	PG0V
8/Ø	BAT-	18	BAT-
9/Ø	FG	Shell	FG

EC3P-B0718-XX

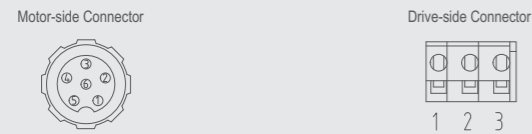
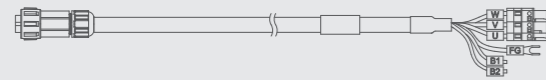

Pin Number	Signal	Pin Number	Signal
1	U	1	U
2	V	2	V
3	W	3	W
4	FG	Crimp Terminal	FG
5	B1	5	B1
6	B2	6	B2

EC3P-N0718-XX

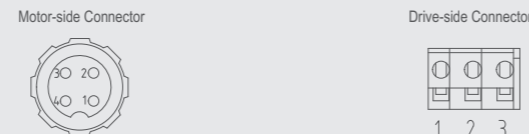

Pin Number	Signal	Pin Number	Signal
1	U	1	U
2	V	2	V
3	W	3	W
4	FG	Crimp Terminal	FG

PBP-GM24-XX

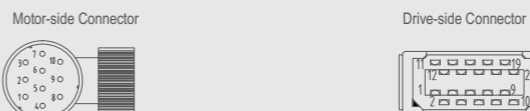

Pin Number	Signal	Pin Number	Signal
1	S+	7	S+
2	S-	8	S-
5	MA+	5	MA+
6	MA-	6	MA-
8	PG5V	9	PG5V
7	PG0V	19	PG0V
10	FG	Shell	FG

PDP-GA24-XX- II

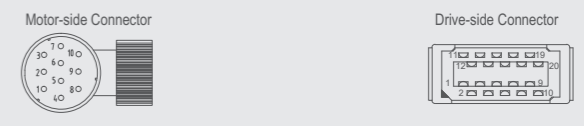
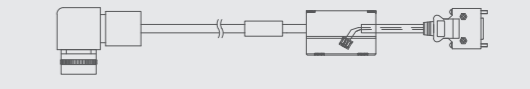

Pin Number	Signal	Pin Number	Signal
1	S+	7	S+
2	S-	8	S-
3	BAT+	17	BAT+
4	BAT-	18	BAT-
8	PG5V	9	PG5V
7	PG0V	19	PG0V
10	FG	Shell	FG

PDM-JE18-XX

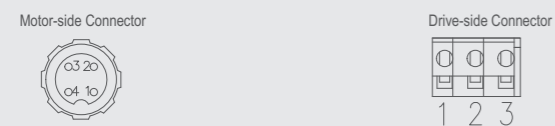

Pin Number	Signal	Pin Number	Signal
1	U	1	U
2	V	2	V
3	W	3	W
4	FG	Crimp Terminal	FG

PBP-GJ24-XX

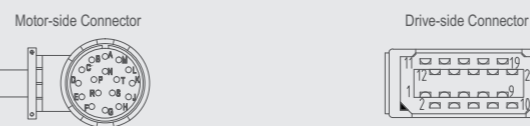

Pin Number	Signal	Pin Number	Signal
K	S+	7	S+
L	S-	8	S-
N	BAT+	5	MA+
P	BAT-	6	MA-
H	PG5V	9	PG5V
G	PG0V	19	PG0V
J	FG	Shell	FG

PDP-GA24-XX

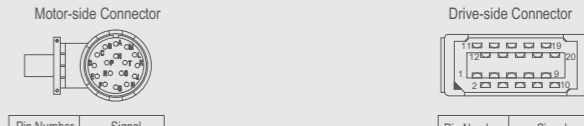
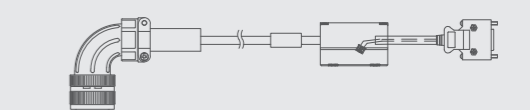

Pin Number	Signal	Pin Number	Signal
K	S+	7	S+
L	S-	8	S-
T	BAT+	17	BAT+
S	BAT-	18	BAT-
H	PG5V	9	PG5V
G	PG0V	19	PG0V
J	FG	Shell	FG

PRP-BA24-XX

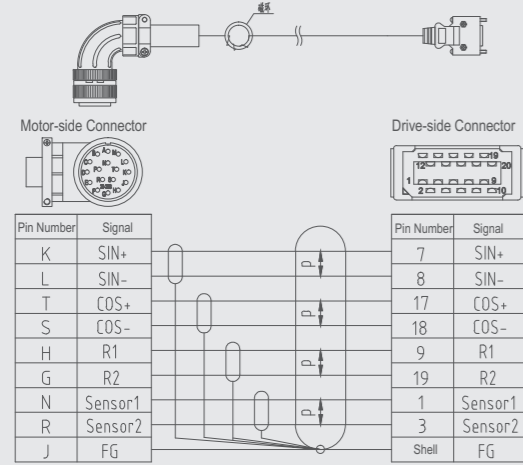

EC3S-A2724-XX

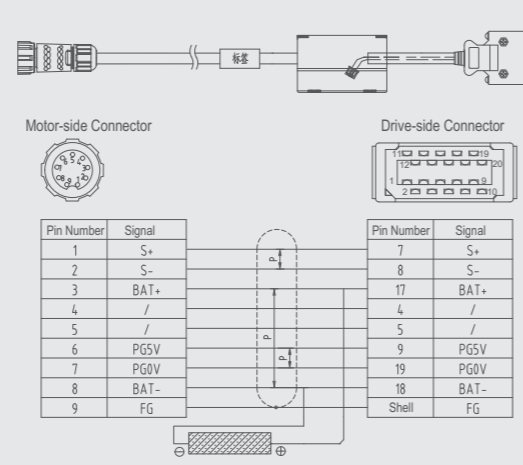

EC3S-I2724-XX

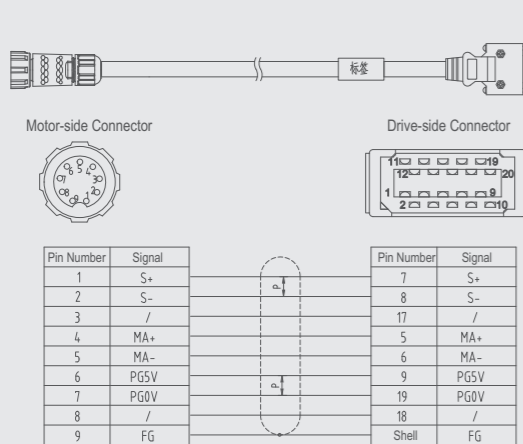

PBP-JE24-XX

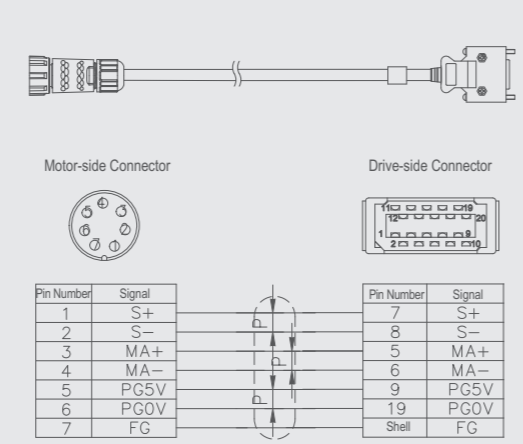

PDP-JE24-XX

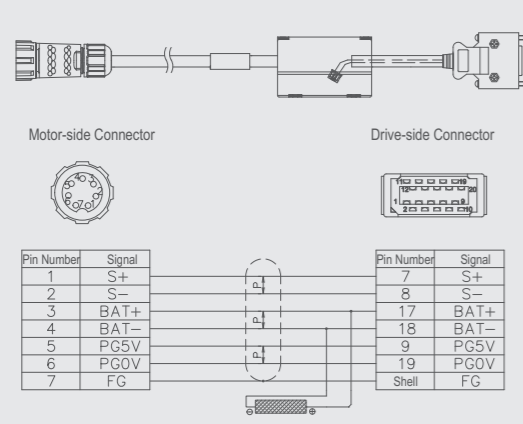

Optional Accessories

Specification		Accessories			
Servo Drive	Main circuit voltage	Built-in Regenerative Resistor Specifications (self-procurement)	Min.Allowable Resistance	Rated Input Minimum Current Of Three-phase Filter (self-procurement)	Min.Rated Current for Circuit Breaker (self-procurement)
ProNet-A5A	200-230VAC	-	25	-	5A
ProNet-01A	200-230VAC	-	25	-	5A
ProNet-02A	200-230VAC	-	25	-	10A
ProNet-04A	200-230VAC	-	25	-	10A
ProNet-08A	200-230VAC	50 /60W	25	-	25A
ProNet-10A	200-230VAC	50 /60W	25	-	25A
ProNet-15A	200-230VAC	40 /80W	25	-	35A
ProNet-20A	200-230VAC	40 /80W	25	-	55A
ProNet-30A	200-230VAC	10 /300W	10	27A	70A
ProNet-50A	200-230VAC	10 /300W	10	42A	100A
ProNet-10D	380-440VAC	200 /80W	50	-	12A
ProNet-15D	380-440VAC	200 /80W	50	-	20A
ProNet-20D	380-440VAC	200 /80W	40	-	24A
ProNet-30D	380-440VAC	40 /300W	35	14A	33A
ProNet-50D	380-440VAC	40 /300W	20	23A	55A
ProNet-70D	380-440VAC	40 /300W	20	27A	60A
ProNet-75D	380-440VAC	40 /300W	20	27A	60A
ProNet-1AD	380-440VAC	20 /1.5KW external connection	17	42A	80A
ProNet-1ED	380-440VAC	15 /1.5KW external connection	12	57A	120A
ProNet-2BD	380-440VAC	10 /3KW=2X20 /1.5KW external parallel connection	8	82A	160A